



# Bread Lines

# 02

*Bread Line 180 is very flexible and space saving. It has a capacity of 750-1800 pieces/hour and a weight range between 100-1500 grams.*

## FOR WHO?

Bakeries.

### WHY BREAD LINE 180?



Silent Operation



Energy Efficient



Easy to clean



### MEASUREMENTS AND DRAWINGS [MM]

*Bread Line 180*

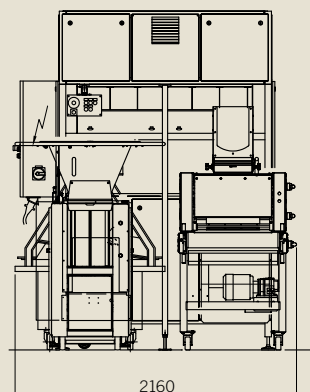
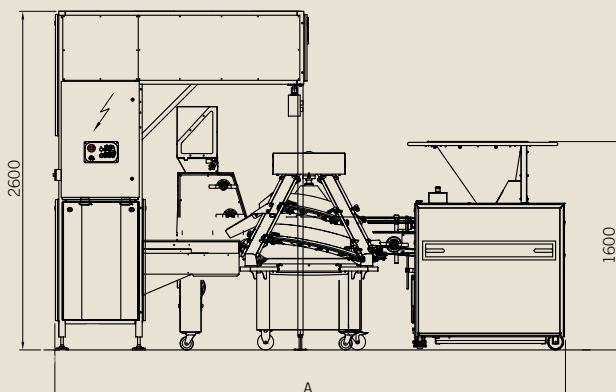

A  
1200 pcs/h = 3390 mm  
1800 pcs/h = 3920 mm

# Bread Line

## BREAD LINE 180

*An user-friendly and flexible bread line with high capacity and efficiency. The line, with a capacity of up to 1800 pcs/hour, handles a variety of dough types and bread sizes.*

### FEATURES AND BENEFITS

High capacity, up to 1800pcs/h.

Weight range 100-1500 g.

For production down to 100 gr a Mini piston and adapter accessory is required.

Proofing time depending on capacity pcs/h and size of intermediate proofer IPP.

Labour saving, consistent production.

Flexible bread line for a variety of doughs and bread types.

Common E-Stop (option on IPP).

### TECHNICAL

Capacity range .....	750-1800 pieces/hour.
Weight range .....	100-1500 g.
Recommended Fuse (amp)* .....	16 - 25 A.
Power supply (for component example on this page) .....	6.38 kW.

\* Depending on connected make-up machines.

### COMPONENTS SET-UP EXAMPLE



#### SD180

Weight range 120-1600 g.  
Variable speed with frequency converter 750-1800 pcs/h, 90 liter stainless steel hopper, non-stick coated.



#### CR400

Centrally adjustable non-stick coated tracks, infeed at 6h, outfeed at 12h, outfeed chute and mechanical flour duster.



#### IPP6/22

Intermediate Pocket Proofer with 132 effective pockets, single infeed V-belt conveyor L=750 mm. Photocell controlled, non-stick coated, infeed conveyor combined with continuous pocket proofer drive. Variable speed on the proofer. Electric control panel under projecting overhang, electric sockets for Divider, Rounder and Moulder. Max proofing time 4,3 min at 1800 pcs/h.



#### M0300

Moulder with centrally adjustable infeed in hopper, two pair of rollers, pressure board 650x1100 mm, collection tray.

# 04

*Bread Line 180 Direct is very flexible and space saving. It has a capacity of 750-1800 pieces/hour and a weight range between 120-1600 grams.*

## FOR WHO?

Bakeries.

### WHY BREAD LINE 180 DIRECT?



Silent Operation



Energy Efficient



Easy to clean



Movable

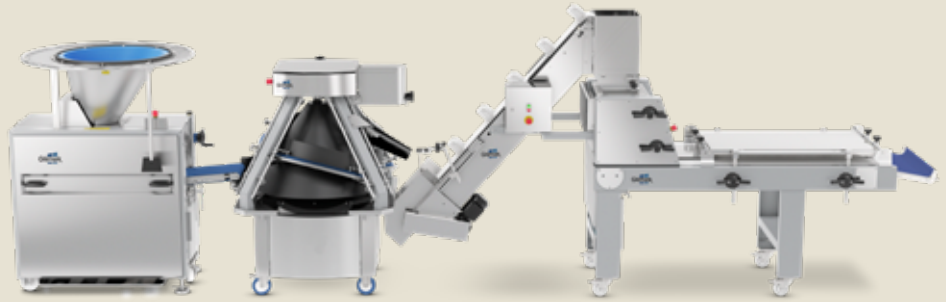

### MEASUREMENTS AND DRAWINGS [MM]

*Bread Line 180 Direct*

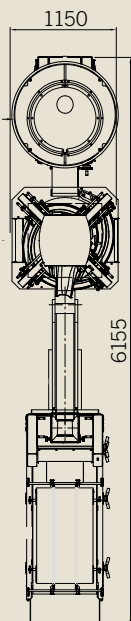

Alt 1

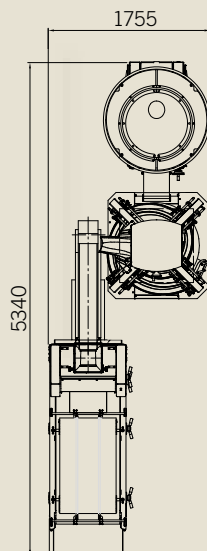

Alt 2

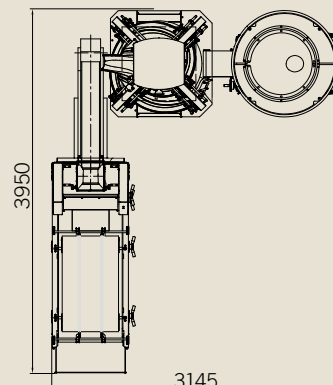
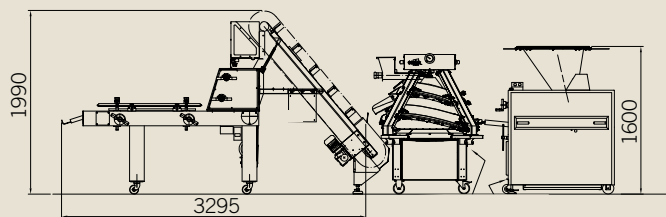

Alt 3

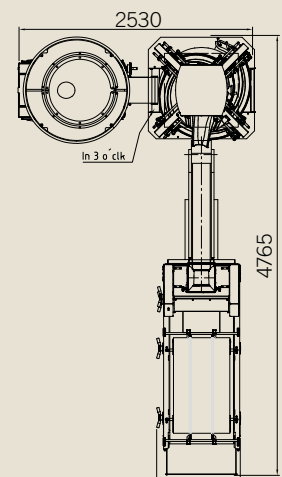

Alt 4

# Bread Line

## BREAD LINE 180 DIRECT

*Specially made for producing bread without need for an intermediate proofing time. A very compact bread line with capacity of up to 1800 pcs/h.*

### FEATURES AND BENEFITS

- Specially made for producing breads without an intermediate proofing time.
- Very compact bread line with a high capacity - 1800 pcs/h.
- Flexible breadline which handles a variety of doughs.
- Labour, time and space saving bread line.
- Flexible and consistent production.

### TECHNICAL

Capacity range	750-1800 pieces/hour.
Weight range	120-1600 g.
Recommended Fuse (amp)*	18 A.
Power supply (for component example on this page)	3.95 kW.

\* Depending on connected make-up machines.

### COMPONENTS SET-UP EXAMPLE



**SD180**  
Weight range 120-1600 g.  
Variable speed with frequency converter 750-1800 pcs/h, 90 liter stainless steel hopper, non-stick coated.



**CR400**  
Centrally adjustable non-stick coated tracks, infeed at 6h, outfeed at 12h, outfeed chute and mechanical flour duster.



**CE100**  
Mounted on moulder M0300, photocell controlled, working step by step to link up cone rounder with Moulder, including electrical cabinet mounted on elevator.  
Weight range: 50-1500 g.



**M0300**  
Moulder with centrally adjustable infeed in hopper, two pair of rollers, pressure board 650x1100 mm, collection tray.

*Bread Line 300 is made for heavy-duty industrial work. It has a capacity up to 3000 pieces/hour and a weight range between 100-1500 grams.*

## FOR WHO?

Semi-Industrial Bakeries.  
Industrial Bakeries.

## WHY BREAD LINE 300?



Silent Operation



Energy Efficient



Easy to clean



## MEASUREMENTS AND DRAWINGS [MM]

*Bread Line 300 /  
Bread Line 300 Stainless Steel*

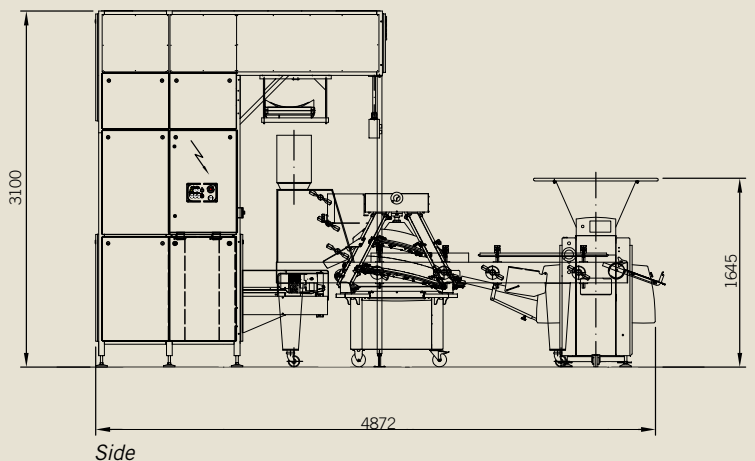
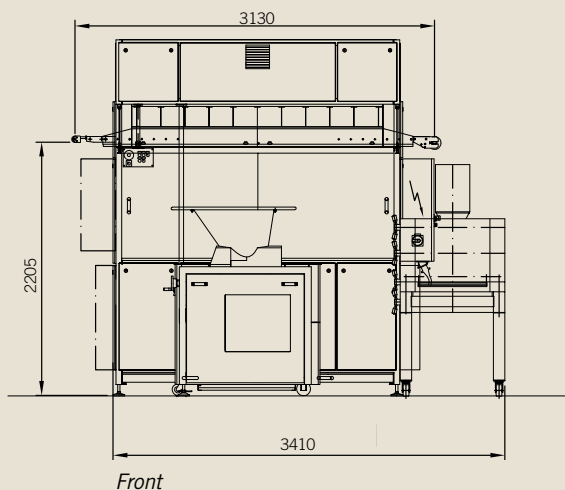

# Industrial Bread Line

## BREAD LINE 300

*Heavy-duty bread line. All machines are designed for continual bread processing and made of high quality materials that ensures excellent baking results. Flexible choice between SD300 or SD600 with stainless steel frame.*

### FEATURES AND BENEFITS

Capacity up to 3000 pcs/h.

Weight range 100-1500 gr.

Proofing time depending on capacity pcs/h and size of intermediate proofer IPP.

Common E-Stop (option on IPP).

### TECHNICAL

SD300 + CR400 + IPP10/48 + M0881 (Basic execution)	
Recommended Fuse (amp)**	16 - 25 A.
Power supply	6.63 kW.
Compressed air	6 bar.
SD300 + CR400 + IPP10/48 + M0881* (Basic execution)	
Recommended Fuse (amp)**	16 - 25 A.
Power supply	6.63 kW.
Compressed air	6 bar.
SD600 + CR400 + IPP10/48 + M0881 (Basic execution)	
Recommended Fuse (amp)**	16 - 25 A.
Power supply	8.63 kW.
Compressed air	6 bar.
SD600 + CR400 + IPP10/48 + M0881* (Basic execution)	
Recommended Fuse (amp)**	16 - 25 A.
Power supply	8.63 kW.
Compressed air	6 bar.

\* With stainless steel frame.

\*\* Depending on connected make-up machines.

### COMPONENTS SET-UP EXAMPLE



#### SD300

Capacity 1500-3000 pcs/h and weight range 150-1150 gr as 2-pocket, capacity 750-1500 pcs/h and weight range 250-2300 gr as 1-pocket. Variable speed with frequency converter, PLC Touch screen panel, 90 liter stainless steel hopper, non-stick coated.



#### SD600

Stainless steel multi pocket divider, weight range 150-1000 gr as 3-pocket and 250-1700/100-700 gr as 2/4 pocket. Variable speed with frequency converter, PLC Touch screen panel, 100 liter stainless steel hopper, non-stick coated.



#### CR400

With centrally adjustable non-stick coated tracks, infeed at 6h, outfeed at 12h, outfeed chute and mechanical flour duster.



#### IPP10/48

With dual infeed conveyor L = 750 mm, centrally placed, photocell controlled, non-stick coated infeed V-belt conveyors. Flap system guides the dough pieces after the rounder. Compressed air is required, 6 bar. Variable speed on the proofer. Electric control panel under projecting overhang, electric sockets for divider, rounder and moulder, outfeed cross conveyor. Proofing time 9,3 min at 3000 pcs/h.



#### M0881

Heavy duty moulder with centrally adjustable infeed in the hopper, three pair of rollers, timing belt drive, two separate pressure boards and collection tray.

# Our story

---

*We provide customized baking solutions, dough handling equipment systems and complete bread lines for professional baking businesses.*

We offer reliable technology with precision control and flexibility regarding weights and types of dough and also user-friendly design that gives baking professionals creative freedom at the lowest cost of ownership.

Sveba Dahlen AB  
Industrivägen 8  
513 82 Fristad, Sweden

[www.sveba.com](http://www.sveba.com)  
[info@glimek.com](mailto:info@glimek.com)

